



AGRICULTURAL MACHINERY  
**sitrex**®

## **SPARE PARTS LIST**

**TCL/TCM/TCM-R/3TCM-R  
TCP/3TCP**

**MOUNTED SPRING TINE  
CULTIVATORS**

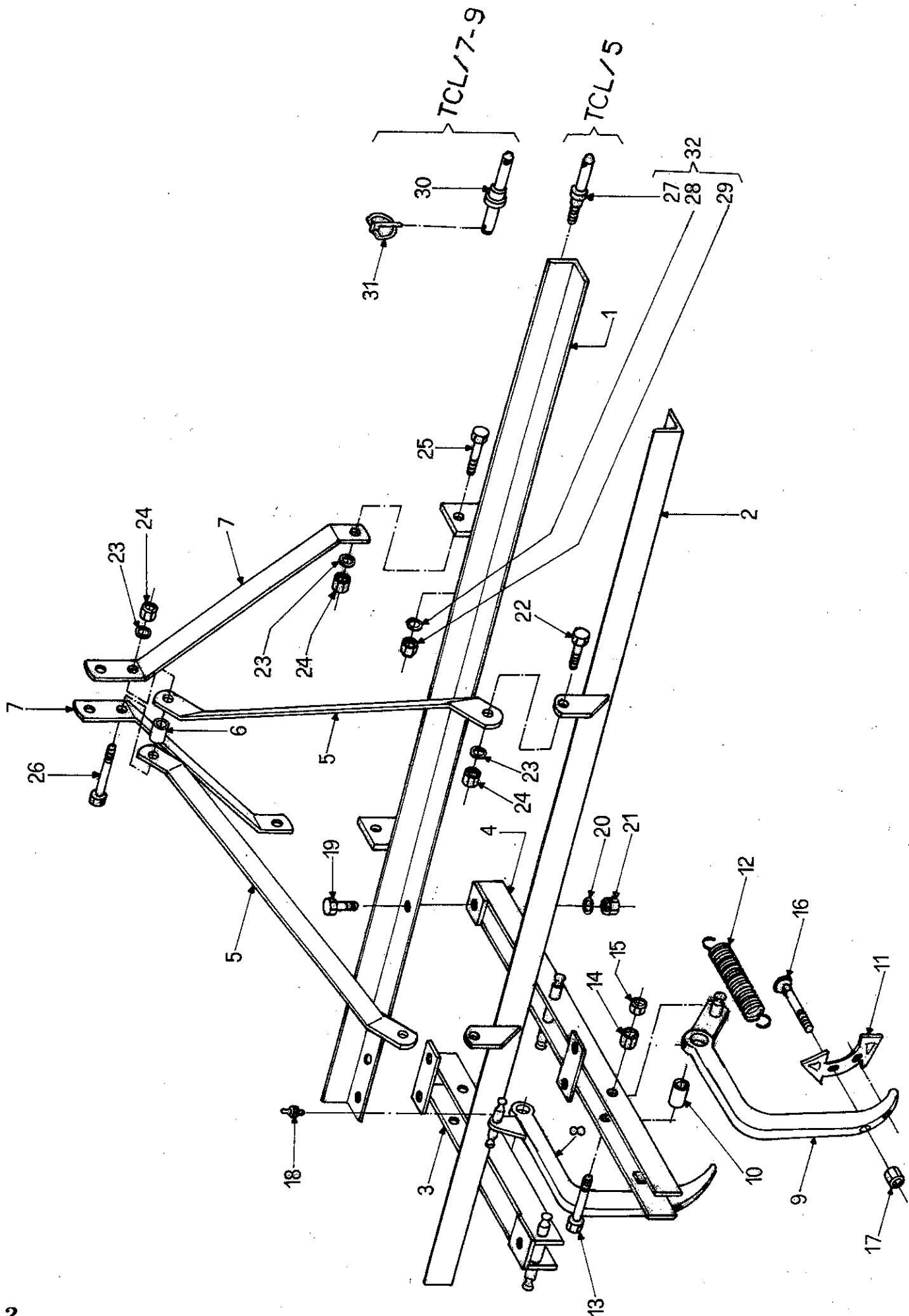

TABLE NO. 930.001

TILLER						
ITEM	TCL/5 Q.ty	TCL/7 Q.ty	TCL/9 Q.ty	PART NO	DESCRIPTION	NOTE
1	1	*	*	300.001	FRONT BAR	
1	*	1	*	300.003	FRONT BAR	
1	*	*	1	300.005	FRONT BAR	
2	1	*	*	300.002	REAR BAR	
2	*	1	*	300.004	REAR BAR	
2	*	*	1	300.006	REAR BAR	
3	3	4	5	300.007	SHORT FRAME	
4	2	3	4	300.008	LONG FRAME	
5	2	*	*	300.011	POINT	
5	*	2	*	300.099	POINT	
5	*	*	2	300.100	POINT	
6	1	1	1	300.048	SPACER	
7	2	*	*	300.009	SUPPORT	
7	*	2	2	300.010	SUPPORT	
8	3	4	5	300.063	FRONT TINE	
9	2	3	4	300.064	REAR TINE	
10	5	7	9	300.047	BUSHING	
11	5	7	9	300.065	SHARE	
12	10	14	18	200.069	SPRING	
13	5	7	9	600.030	SCREW	
14	5	7	9	600.083	NUT	
15	5	7	9	600.081	NUT	
16	10	14	18	610.276	SCREW	
17	10	14	18	600.050	NUT	
18	5	7	9	600.034	GREASE NIPPLE	
19	15	21	27	600.065	SCREW	
20	15	21	27	600.086	SPRING WASHER	
21	15	21	27	600.009	NUT	
22	2	2	2	600.176	SCREW	
23	5	5	5	600.180	SPRING WASHER	
24	5	5	5	600.084	NUT	
25	2	2	2	600.174	SCREW	
26	1	1	1	600.178	SCREW	
27	2	*	*	305.077	PIN	
28	2	*	*	600.246	SPRING WASHER	
29	2	*	*	600.244	NUT	
30	*	2	2	300.049	PIN	
31	*	2	2	600.017	SPLIT PIN	
32	2	*	*	300.046	PIN ASSY	

# TCM/TCM-R

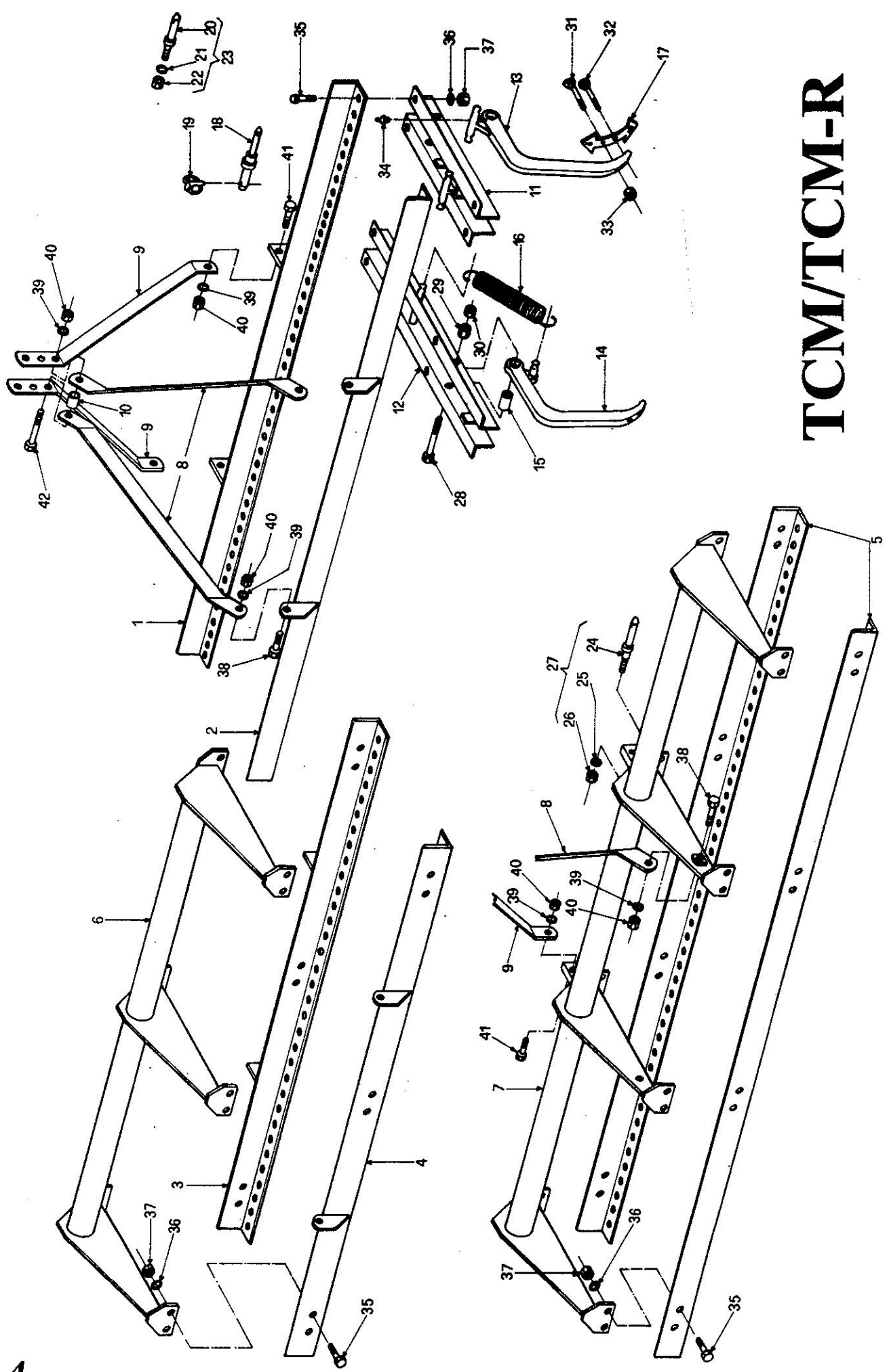

TABLE NO. 930.002/1

TABLE NO. 930.002/2

TABLE NO. 930.002/1				TABLE NO. 930.002/2								
ITEM	TCM/5	TCM/7	TCM/9	TCM/11	PART NO	DESCRIPTION	ITEM	TCM/7R	TCM/9R	TCM/11R	TCM/13R	TCM/15R
	Q.ty	Q.ty	Q.ty	Q.ty				Q.ty	Q.ty	Q.ty	Q.ty	Q.ty
1	1				300.016	FRONT BAR	3	1				300.050
1		1			300.018	FRONT BAR	3		1			300.063
1			1		300.020	FRONT BAR	4	1				300.051
1				1	300.022	FRONT BAR	4		1			300.054
2	1				300.017	REAR BAR	5			2		300.056
2		1			300.019	REAR BAR	5				2	300.041
2			1		300.021	REAR BAR	5				2	300.043
2				1	300.023	REAR BAR	6	1				300.052
8	2				300.099	POINT	6		1			300.055
8		2			300.012	POINT	7			1		300.057
8			2		300.013	POINT	7				1	300.058
9	2				300.009	SUPPORT	7					300.059
9		2			300.010	SUPPORT	8	2				300.012
10	1	1			300.048	3 POINT SHIM	8		2			300.013
11	3	4	5	6	300.027	SHORT FRAME	8		2	2	2	300.069
12	2	3	4	5	300.026	LONG FRAME	9	2	2	2	2	300.010
13	3	4	5	6	300.061	FRONT TINE	10	1	1	1	1	300.048
14	2	3	4	5	300.062	REAR TINE	11	4	5	6	7	300.027
15	5	7	9	11	300.014	BUSHING	12	3	4	5	6	300.026
16	10	14	18	22	300.015	SPRING	13	4	5	6	7	300.061
17	5	7	9	11	300.065	SPARE	14	3	4	5	6	300.062
18		2	2	2	300.049	PIN	15	7	9	11	13	300.014
19		2	2	2	600.017	SNAP SPLIT PIN	16	14	18	22	26	300.015
20	2				305.077	PIN	17	7	9	11	13	300.065
21	2				600.246	SPRING WASHER	18	2	2			300.049
22	2				600.244	NUT	19	2	2			600.017
23	2				300.046	COMPLETE PIN	24		2	2	2	305.078
28	5	7	9	11	600.030	SCREW	25		2	2	2	600.030
29	5	7	9	11	600.083	NUT	26		2	2	2	600.030
30	5	7	9	11	600.081	NUT	27		2	2	2	300.060
31	5	7	9	11	600.794	SCREW	28	7	9	11	13	600.030
32	5	7	9	11	600.793	SCREW	29	7	9	11	13	600.083
33	10	14	18	22	600.008	NUT	30	7	9	11	13	600.081
34	5	7	9	11	600.034	GREASE NIPPLE	31	7	9	11	13	600.794
35	20	28	36	44	600.065	SCREW	32	7	9	11	13	600.793
36	20	28	36	44	600.086	SPRING WASHER	33	14	18	22	26	600.008
37	20	28	36	44	600.009	NUT	34	7	9	11	13	600.034
38	2	2	2	2	600.176	SCREW	35	40	48	60	68	600.065
39	5	5	5	5	600.180	SPRING WASHER	36	40	48	60	68	600.086
40	5	5	5	5	600.084	NUT	37	40	48	60	68	600.009
41	2	2	2	2	600.174	SCREW	38	2	2	2	2	600.176
42	1	1	1	1	600.178	SCREW	39	5	5	5	5	600.180
							40	5	5	5	5	600.084
							41	2	2	2	2	600.174
							42	1	1	1	1	600.178

# 3TCM-R

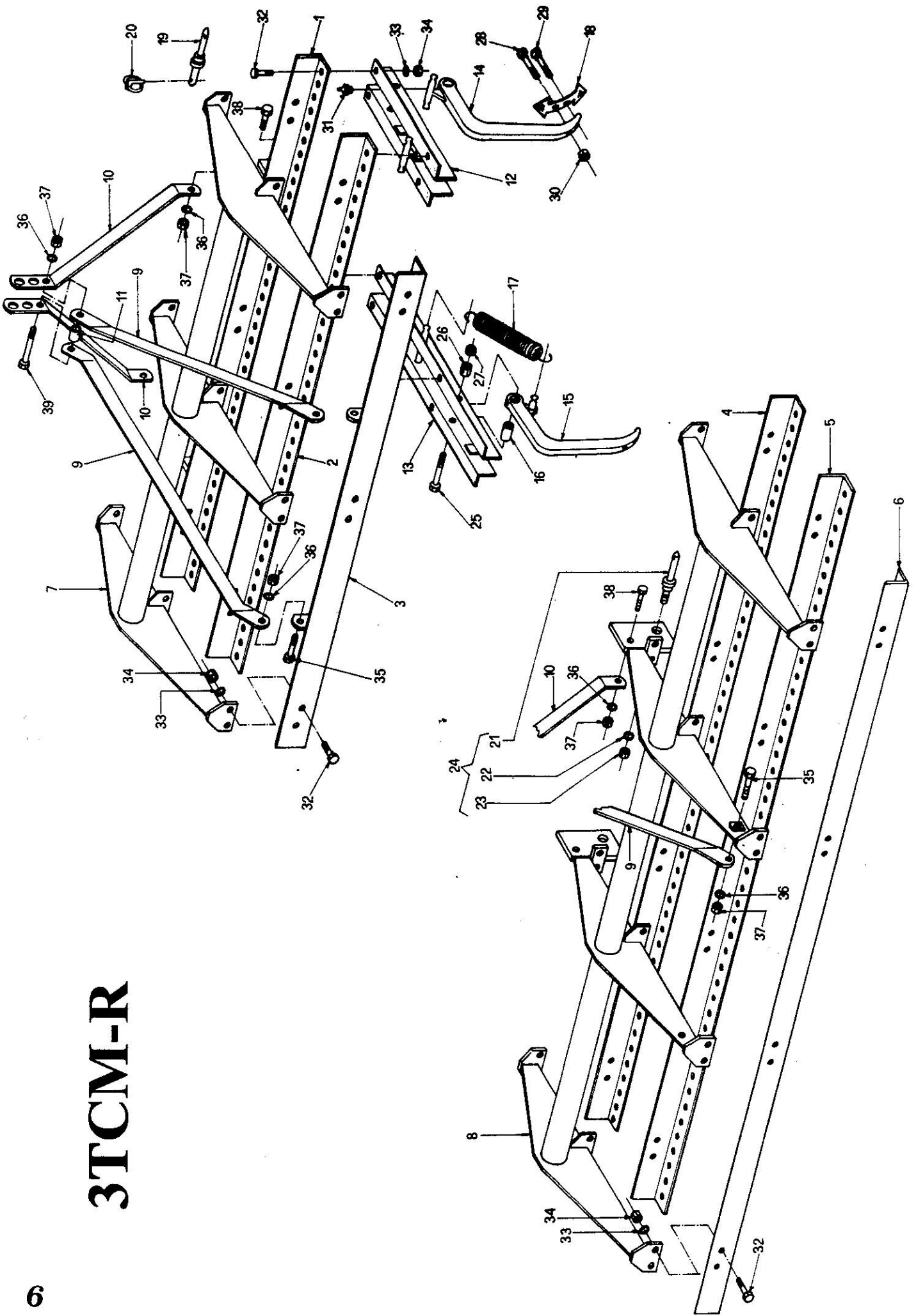

TABLE NO. 930.003

TILLER							
ITEM	3CM/9R Q.ty	3CM/11R Q.ty	3CM/13R Q.ty	3CM/15R Q.ty	PART NO	DESCRIPTION	NOTE
1	1	*	*	*	300.032	FRONT BAR	
2	1	*	*	*	300.033	CENTER BAR	
3	1	*	*	*	300.034	REAR BAR	
4	*	1	*	*	300.037	FRONT BAR	
4	*	*	1	*	300.041	FRONT BAR	
4	*	*	*	1	300.042	FRONT BAR	
5	*	1	*	*	300.038	CENTER BAR	
5	*	*	1	*	300.041	CENTER BAR	
5	*	*	*	1	300.043	CENTER BAR	
6	*	1	1	*	300.038	REAR BAR	
6	*	*	*	1	300.043	REAR BAR	
7	1	*	*	*	300.035	RE-INFORCEMENT	
8	*	1	1	*	300.039	RE-INFORCEMENT	
8	*	*	*	1	300.044	RE-INFORCEMENT	
9	2	2	2	2	300.074	POINT	
10	2	2	2	2	300.010	SUPPORT	
11	1	1	1	1	300.048	SPACER	
12	7	7	9	11	300.027	FRONT FRAME	
13	2	4	4	4	300.026	REAR FRAME	
14	7	7	9	11	300.061	FRONT TINE	
15	2	4	4	4	300.062	REAR TINE	
16	9	11	13	15	300.014	BUSHING	
17	18	22	26	30	300.015	SPRING	
18	9	11	13	15	300.065	SHARE	
19	2	*	*	*	300.049	PIN	
20	2	*	*	*	600.017	SPLIT PIN	
21	*	2	2	2	305.078	PIN	
22	*	2	2	2	600.240	SPRING WASHER	
23	*	2	2	2	600.244	NUT	
24	*	2	2	2	300.060	PIN	
25	9	11	13	15	600.030	SCREW	
26	9	11	13	15	600.083	NUT,BIG	
27	9	11	13	15	600.081	NUT,SMALL	
28	9	11	13	15	610.278	SCREW	
29	9	11	13	15	610.277	SCREW	
30	18	22	26	30	600.008	NUT	
31	9	11	13	15	600.034	GREASE NIPPLE	
32	54	68	76	84	600.065	SCREW	
33	54	68	76	84	600.086	SPRING WASHER	
34	54	68	76	84	600.009	NUT	
35	2	2	2	2	600.174	SCREW	
36	5	5	5	5	600.180	SPRING WASHER	
37	5	5	5	5	600.032	NUT	
38	2	2	2	2	600.176	SCREW	
39	1	1	1	1	600.178	SCREW	

# TCP

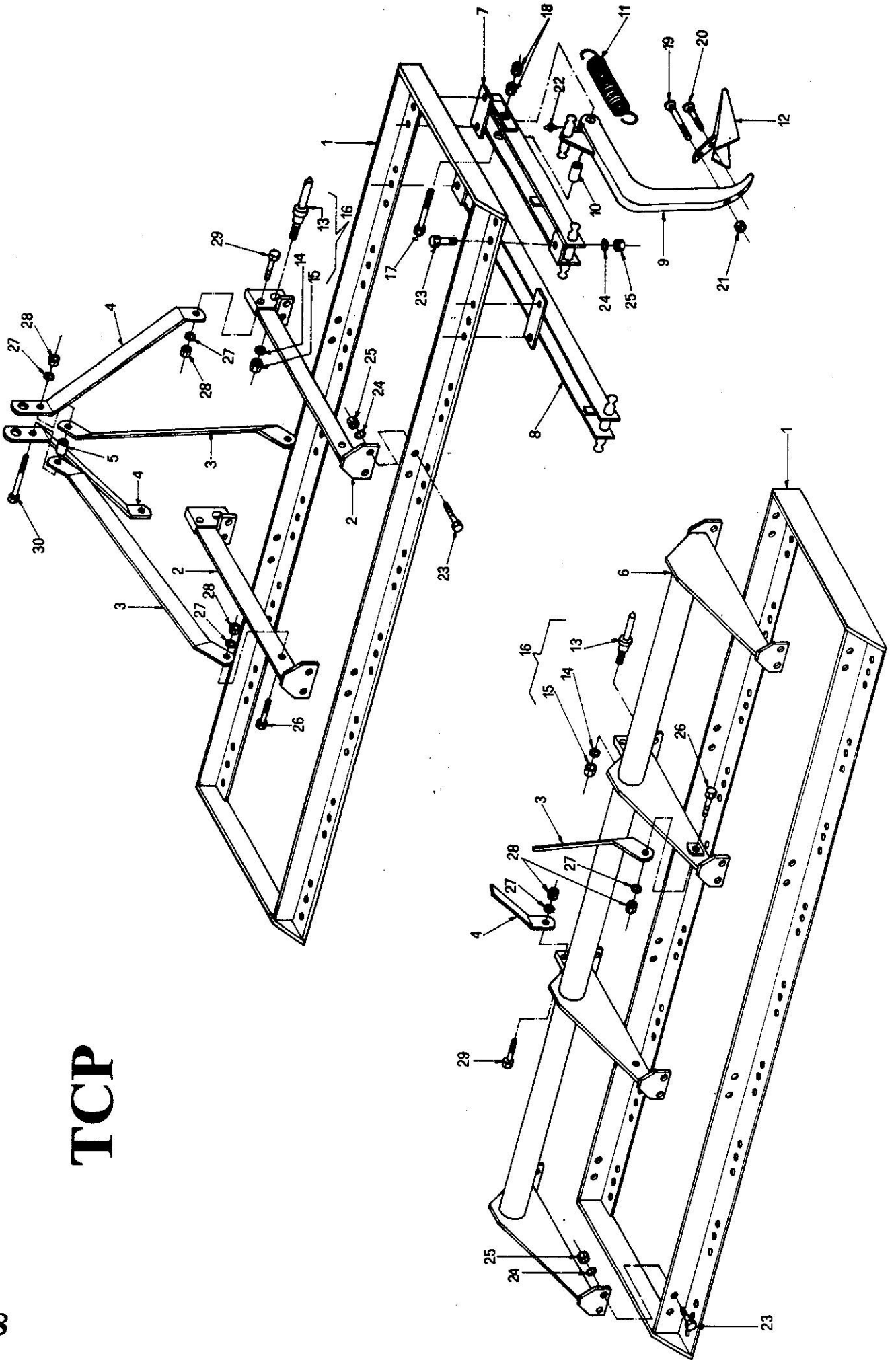



TABLE NO. 930.004

TILLER								
ITEM	TCP/7 Q.ty	TCP/9 Q.ty	TCP/11 Q.ty	TCP/13 Q.ty	TCP/15 Q.ty	PART NO	DESCRIPTION	NOTE
1	1	*	*	*	*	300.070	FRAME	
1	*	1	*	*	*	300.071	FRAME	
1	*	*	1	*	*	300.072	FRAME	
1	*	*	*	1	*	300.076	FRAME	
1	*	*	*	*	1	300.078	FRAME	
2	2	2	2	*	*	300.073	BRACKET	
3	2	2	2	2	2	300.075	POINT	
4	2	2	2	2	2	300.086	SUPPORT	
5	1	1	1	1	1	300.087	SPACER	
6	*	*	*	1	*	300.077	RE-INFORCEMENT	
6	*	*	*	*	1	300.079	RE-INFORCEMENT	
7	4	5	6	7	8	300.089	FRONT FRAME (SMALL)	
8	3	4	5	6	7	300.090	REAR FRAME (SMALL)	
9	7	9	11	13	15	300.025	TINE	
10	7	9	11	13	15	300.031	BUSHING	
11	14	18	22	26	30	300.024	SPRING	
12	7	9	11	13	15	300.068	SHARE	
13	2	2	2	2	2	305.078	PIN	
14	2	2	2	2	2	600.214	SPRING WASHER	
15	2	2	2	2	2	600.249	NUT	
16	2	2	2	2	2	300.060	PIN ASSY	
17	7	9	11	13	15	600.254	SCREW	
18	14	18	22	26	30	600.256	NUT	
19	7	9	11	13	15	610.278	SCREW	
20	7	9	11	13	15	610.277	SCREW	
21	14	18	22	26	30	600.052	NUT	
22	7	9	11	13	15	600.034	GRASE NIPPLE	
23	29	35	41	55	61	600.176	SCREW	
24	29	35	41	55	61	600.180	SPRING WASHER	
25	29	35	41	55	61	600.084	NUT	
26	2	2	2	2	2	600.253	SCREW	
27	5	5	5	5	5	600.259	SPRING WASHER	
28	5	5	5	5	5	600.257	NUT	
29	2	2	2	2	2	600.251	SCREW	
30	1	1	1	1	1	600.255	SCREW	

# 3TCP

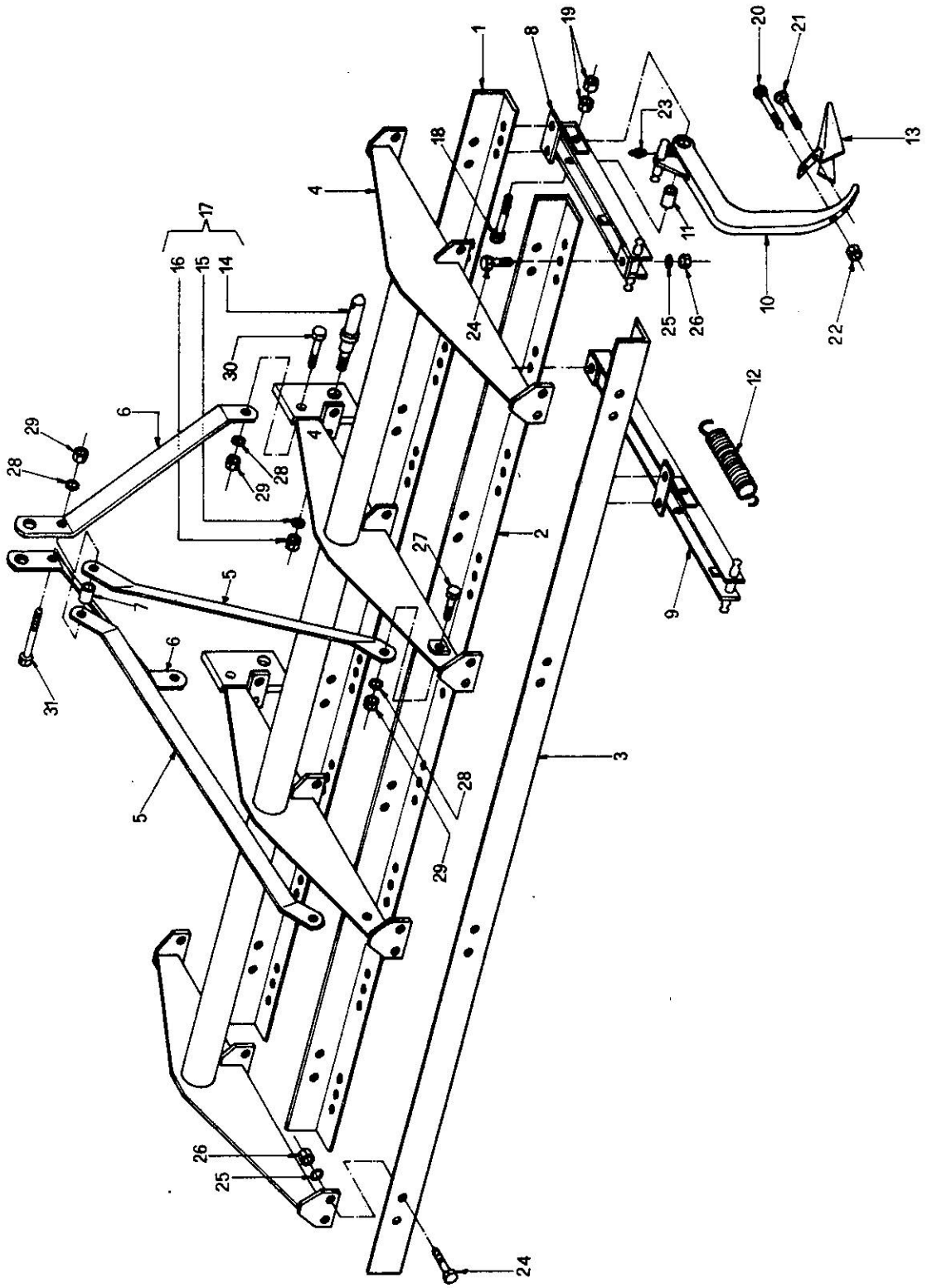
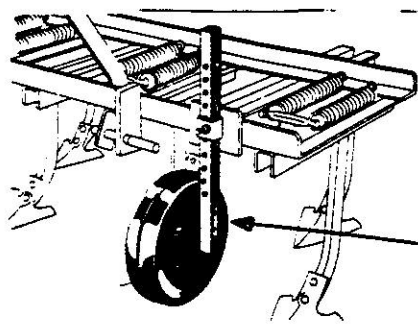

TABLE NO. 930.005

TILLER						
ITEM	3CP/11R Q.ty	3CP/13R Q.ty	3CP/15R Q.ty	PART NO	DESCRIPTION	NOTE
1	1	*	*	300.080	FRONT BAR	
1	*	1	1	300.082	FRONT BAR	
2	1	*	*	300.081	CENTER BAR	
2	*	1	*	300.082	CENTER BAR	
2	*	*	1	300.083	CENTER BAR	
3	1	1	*	300.081	REAR BAR	
3	*	*	1	300.083	REAR BAR	
4	1	1	*	300.084	RE-INFORCEMENT	
4	*	*	1	300.085	RE-INFORCEMENT	
5	2	2	2	300.088	POINT	
6	2	2	2	300.086	SUPPORT	
7	1	1	1	300.087	SPACER	
8	7	9	11	300.089	FRONT FRAME (SMALL)	
9	4	4	4	300.090	REAR FRAME (SMALL)	
10	11	13	15	300.025	TINE	
11	11	13	15	300.031	BUSHING	
12	22	26	30	300.024	SPRING	
13	11	13	15	300.068	SHARE	
14	2	2	2	305.078	PIN	
15	2	2	2	600.214	SPRING WASHER	
16	2	2	2	600.249	NUT	
17	2	2	2	300.060	PIN ASSY	
18	11	13	15	600.254	SCREW	
19	22	26	30	600.256	NUT	
20	11	13	15	610.278	SCREW	
21	11	13	15	610.277	SCREW	
22	22	26	30	600.052	NUT	
23	11	13	15	600.034	GRASE NIPPLE	
24	57	63	69	600.176	SCREW	
25	57	63	69	600.180	SPRING WASHER	
26	57	63	69	600.084	NUT	
27	2	2	2	600.253	SCREW	
28	5	5	5	600.259	SPRING WASHER	
29	5	5	5	600.257	NUT	
30	2	2	2	600.251	SCREW	
31	1	1	1	600.255	SCREW	



Ruotino regolazione profondità  
 Depth adjusting wheels  
 Petites roues de réglage à pro-  
 fondeur

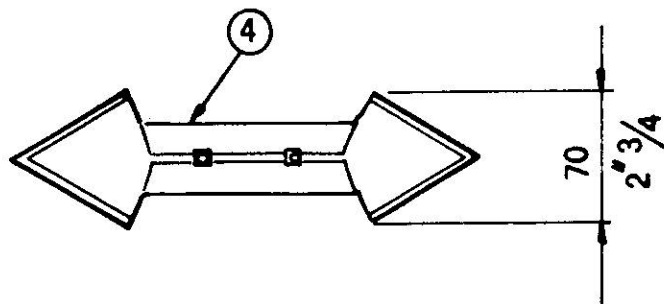
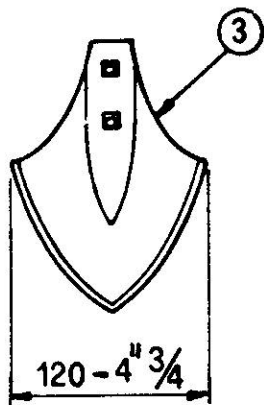
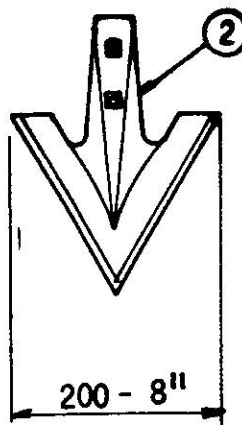
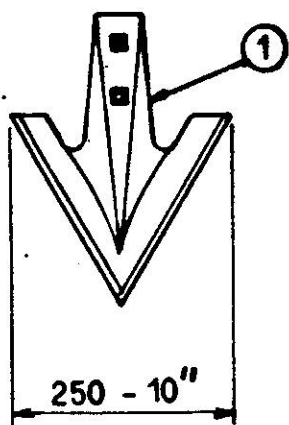
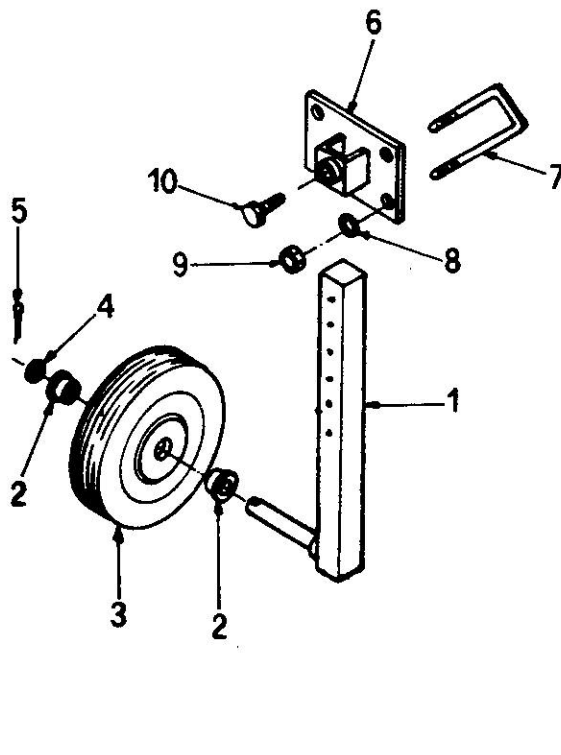

TABLE NO. 930.006				
TILLER				
ITEM	Q.ty	PART NO	DESCRIPTION	NOTE
1	1	300.101	WHEEL SUPPORT	
2	2	300.102	BUSHING	
3	1	300.103	WHEEL	
4	1	600.031	WASHER	
5	1	600.548	SPLIT PIN	
6	1	300.104	HITCH PLATE	
7	2	300.105	U BOLT	
8	4	600.336	WASHER	
9	4	600.032	NUT	
10	1	600.065	SCREW	
11	1	300.092	WHEEL ASSY	TCM
11	1	300.121	WHEEL ASSY	TCL

ITEM	Q.ty	PART NO	DESCRIPTION	NOTE
1	*	300.068	SHARE ,LARGE	
2	*	300.067	SHARE ,MEDIUM	
3	*	300.066	SHARE ,SMALL	
4	*	300.065	SHARE ,REVERSIBLE	



AGRICULTURAL MACHINERY  
**sitrex**®

Zona Industriale-Viale Grecia, 8  
06018 TRESTINA-(Perugia)-ITALY  
Tel. +39.075.8540021-Telefax +39.075.8540523  
e-mail: [sitrex@sitrex.it](mailto:sitrex@sitrex.it) [www.sitrex.com](http://www.sitrex.com)

